

Rank of Stably Dissipative Graphs

Pedro Duarte

*Departamento de Matemática and Cmaf
Faculdade de Ciências
Universidade de Lisboa
Campo Grande, Edifício C6, Piso 2
1749-016 Lisboa, Portugal*

Telmo Peixee

*Departamento de Matemática and Cmaf
Faculdade de Ciências
Universidade de Lisboa
Campo Grande, Edifício C6, Piso 2
1749-016 Lisboa, Portugal*

Abstract

For the class of stably dissipative Lotka-Volterra systems we prove that the rank of its defining matrix, which is the dimension of the associated invariant foliation, is completely determined by the system's graph.

Keywords: Lotka-Volterra system, stably dissipative matrix, reduced graph.

AMS subject classification: 37C65, 93D20, 15A45, 05C50.

1. Introduction

In his work “Leçons sur la Théorie Mathématique de la Lutte pour la Vie” [17] Volterra began the study of differential equations

$$\dot{x}_i(t) = x_i(t) \left(r_i + \sum_{j=1}^n a_{ij} x_j(t) \right), \quad i = 1, \dots, n, \quad (1)$$

where $x_i(t) \geq 0$ represents the density of population i in time t and r_i its intrinsic rate of growth or decay. Each coefficient a_{ij} represents the effect of population j on population i . If $a_{ij} > 0$ this means that population i benefits from population j . $A = (a_{ij})$ is said

to be the interaction matrix of the system (1). This system of differential equations is usually referred to as the Lotka-Volterra equations.

For two-dimensional systems we can completely analyze the dynamics of (1) (see, for example, [5]). However we are far from being capable of doing the same for higher dimensional Lotka-Volterra systems, in spite of some important results [11, 16, 2, 21].

There is a close relation between studying the dynamical properties of a Lotka-Volterra system and the algebraic properties of its interaction matrix, and depending on that these systems can be classified in three main classes: *cooperative* or *competitive*; *conservative*; and *dissipative*.

For the *cooperative* and *competitive* systems, overall results were obtained by Smale [14] and Hirsch [3, 4], among others, for example, Zeeman [18, 19, 20], Van Den Driessche *et al.* [1], Hofbauer *et al.* [6], Smith [15] and Karakostas *et al.* [7].

Concerning the *conservative* systems, the initial investigations are attributed to Volterra, who also defined the class of *dissipative* systems [17] looking for a generalization of the predator-prey system. Given $A \in \text{Mat}_{n \times n}(\mathbb{R})$ and a point $q \in \mathbb{R}_+^n$ we can write the Lotka-Volterra system (1) as

$$\frac{dx}{dt} = X_{A,q}(x), \quad (2)$$

where $X_{A,q}(x) = x * A(x - q)$. The symbol ‘ $*$ ’ denotes point-wise multiplication of vectors in \mathbb{R}^n . We say that system (2), the matrix A , or the vector field $X_{A,q}$, are *dissipative* iff there is a positive diagonal matrix D such that $Q(x) = x^T A D x \leq 0$ for every $x \in \mathbb{R}^n$. Notice this condition is equivalent to $x^T D^{-1} A x \leq 0$, because

$$x^T D^{-1} A x = (D^{-1} x)^T A D (D^{-1} x) = Q(D^{-1} x) \leq 0.$$

When A is dissipative, (2) admits the Lyapunov function

$$h(x) = \sum_{i=1}^n \frac{x_i - q_i \log x_i}{d_i}, \quad (3)$$

which decreases along orbits of $X_{A,q}$. In fact the derivative of h along orbits of $X_{A,q}$ is

$$\dot{h} = \sum_{i,j=1}^n \frac{a_{ij}}{d_i} (x_i - q_i)(x_j - q_j) = (x - q)^T D^{-1} A (x - q) \leq 0. \quad (4)$$

Since h function is proper, $X_{A,q}$ determines a complete semi-flow $\phi_{A,q}^t : \mathbb{R}_+^n \leftrightarrow$, defined for all $t \geq 0$. Let $\Gamma_{A,q}$ denote the forward limit set of (2), i.e., the set of all accumulation

points of $\phi_{A,q}^t(x)$ as $t \rightarrow +\infty$, sometimes referred to as the system's attractor. By La Salle's theorem [8] we know that for dissipative systems $\Gamma_{A,q} \subseteq \{\dot{h} = 0\}$.

The notion of *stably dissipative* is due to Redheffer *et al.*, who in a series of papers in the 80's [12, 13, 11, 9, 10] studied the asymptotic stability of this class of systems, using the term *stably admissible* systems. Redheffer *et al.* designated by *admissible* the matrices that Volterra had initially classified as *dissipative* [17]. We now give the precise definition of stably dissipative system. Given a matrix $A \in \text{Mat}_{n \times n}(\mathbb{R})$ we say that another real matrix $\tilde{A} \in \text{Mat}_{n \times n}(\mathbb{R})$ is a *perturbation of A* iff

$$\tilde{a}_{ij} = 0 \Leftrightarrow a_{ij} = 0.$$

We say that a given matrix A , $X_{A,q}$, or (2), is *stably dissipative* iff any sufficiently small perturbation \tilde{A} of A is dissipative, i.e.,

$$\exists \epsilon > 0 : \max_{i,j} |a_{ij} - \tilde{a}_{ij}| < \epsilon \Rightarrow \tilde{A} \text{ is dissipative.}$$

From the interaction matrix A we can construct a graph G_A having as vertices the n species $\{1, \dots, n\}$. See definition 3.1 below. An edge is drawn connecting the vertices i and j whenever $a_{ij} \neq 0$ or $a_{ji} \neq 0$. Redheffer *et al.* [12, 13, 11, 9, 10] have characterized the class of stably dissipative systems and its attractor $\Gamma_{A,q}$ in terms of the graph G_A . In particular, they describe a simple reduction algorithm, running on the graph G_A , that 'deduces' every restriction of the form $\Gamma_{A,q} \subseteq \{x : x_i = q_i\}$, $1 \leq i \leq n$, that holds for every stably dissipative system with interaction graph G_A . To start this algorithm they use the following

Lemma 1.1. *Given a stably dissipative matrix A , there is some positive diagonal matrix D such that*

$$\sum_{i,j=1}^n \frac{a_{ij}}{d_i} w_i w_j = 0 \quad \Rightarrow \quad a_{ii} w_i = 0, \quad \forall i = 1, \dots, n.$$

Since by La Salle's theorem

$$\Gamma_{A,q} \subseteq \left\{ x \in \mathbb{R}_+^n : \sum_{i,j=1}^n \frac{a_{ij}}{d_i} (x_i - q_i)(x_j - q_j) = 0 \right\},$$

it follows that $\Gamma_{A,q} \subseteq \{x : x_i = q_i\}$ for every $i = 1, \dots, n$ such that $a_{ii} < 0$. A vertex i is colored black, \bullet , to state that $\Gamma_{A,q} \subseteq \{x : x_i = q_i\}$ holds. Similarly, a cross is drawn

at a vertex i , \oplus , to state that $\Gamma_{A,q} \subseteq \{x : X_{A,q}^i(x) = 0\}$, which means $\{x_i = \text{const}\}$ is an invariant foliation under $\phi_{A,q}^t : \Gamma_{A,q} \leftarrow$. All other vertices are coloured white, \circ . Before starting their procedure, as $a_{ii} \leq 0$ for all i , they colour in black every vertex $i \in \{1, \dots, n\}$ such that $a_{ii} < 0$, and in white all other vertices. This should be interpreted as a collection of statements about the attractor $\Gamma_{A,q}$. The reduction procedure consists of the following rules, corresponding to valid inference rules:

- (a) If j is a \bullet or \oplus -vertex and all of its neighbours are \bullet , except for one vertex l , then colour l as \bullet ;
- (b) If j is a \bullet or \oplus -vertex and all of its neighbours are \bullet or \oplus , except for one vertex l , then draw \oplus at the vertex l ;
- (c) If j is a \circ -vertex and all of its neighbours are \bullet or \oplus , then draw \oplus at the vertex j .

Redheffer *et al.* define the *reduced graph* of the system, $\mathcal{R}(A)$, as the graph obtained from G_A by successive applications of the reduction rules (a), (b) and (c) until they can no longer be applied. In [11] Redheffer and Walter proved the following result, which in a sense states that the previous algorithm on G_A can not be improved.

Theorem 1.2. *Given a stably dissipative matrix A ,*

- (a) *If $\mathcal{R}(A)$ has only \bullet -vertices then A is nonsingular, the stationary point q is unique and every solution of (2) converges, as $t \rightarrow \infty$, to q .*
- (b) *If $\mathcal{R}(A)$ has only \bullet and \oplus -vertices, but not all \bullet , then A is singular, the stationary point q is not unique, and every solution of (2) has a limit, as $t \rightarrow \infty$, that depends on the initial condition.*
- (c) *If $\mathcal{R}(A)$ has at least one \circ -vertex then there exists a stably dissipative matrix \tilde{A} , with $G_{\tilde{A}} = G_A$, such that the system (2) associated with \tilde{A} has a nonconstant periodic solution.*

In a very recent paper, Zhao and Luo [21] gave necessary and sufficient conditions for a matrix to be stably dissipative, see proposition 3.5.

The previous theorem tells us that when $\mathcal{R}(A)$ has only \bullet -vertices, then the matrix A has always maximal rank, $\text{rank}(A) = n$. In case $\mathcal{R}(A)$ has only \bullet and \oplus -vertices, then rank of the matrix A equals the dimension of an invariant foliation. This led us to establish that the rank of any stably dissipative matrix only depends on its graph.

In particular the same is true for the dimension of the invariant foliation of any stably dissipative system. See theorem 4.2 and corollary 4.3 of section 4.

2. Dissipative Systems and Invariant Foliations

Assume the Lotka-Volterra field $X_{A,q}(x) = x * A(x - q)$, defined in (2), is associated with a dissipative matrix A with $\text{rank}(A) = k$. Let W be a $(n - k) \times n$ matrix whose rows form a basis of

$$\text{Ker}(A^T) = \{ x \in \mathbb{R}^n : x^T A = 0 \}.$$

Define the map $g : \mathbb{R}_+^n \rightarrow \mathbb{R}^{n-k}$, $g(x) = W \log x$, where $\log x = (\log x_1, \dots, \log x_n)^T$. Denoting by $D_x = \text{diag}(x_1, \dots, x_n)$ the diagonal matrix, the jacobian matrix of g , $Dg_x = W D_x^{-1}$, has maximal rank $n - k$. Hence $g : \mathbb{R}_+^n \rightarrow \mathbb{R}^{n-k}$ is a submersion.

We denote by \mathcal{F}_A the pre-image foliation, whose leaves are the pre-images $g^{-1}(c)$ of g . By a classical theorem on Differential Geometry, each non-empty pre-image $g^{-1}(c)$ is a submanifold of dimension k . Recall that the dimension of a foliation is the common dimension of its leaves. A foliation \mathcal{F} is said to be invariant under a vector field X if $X(x) \in T_x \mathcal{F}$ for every x , where $T_x \mathcal{F}$ denotes the tangent space at x to the unique leaf of \mathcal{F} through x . This condition is equivalent to say that the flow of X preserves the leaves of \mathcal{F} .

Proposition 2.1. *If A is dissipative then the foliation \mathcal{F}_A is $X_{A,q}$ -invariant with $\dim(\mathcal{F}_A) = \text{rank}(A)$.*

Proof. We have

$$\begin{aligned} Dg_x(X_{A,q}(x)) &= Dg_x(D_x A(x - q)) \\ &= W D_x^{-1} D_x A(x - q) \\ &= W A(x - q) = 0, \end{aligned}$$

because $W A = 0$. Hence $X_{A,q}(x) \in T_x \mathcal{F}_A$ and \mathcal{F}_A is $X_{A,q}$ -invariant. \square

Defining the *symmetric* and *skew-symmetric parts* of a matrix A by

$$A^{\text{sym}} = \frac{A + A^T}{2} \quad \text{and} \quad A^{\text{skew}} = \frac{A - A^T}{2},$$

the following decompositions hold

$$A = A^{\text{sym}} + A^{\text{skew}} \quad \text{and} \quad A^T = A^{\text{sym}} - A^{\text{skew}} .$$

The following lemma is a simple but key observation

Lemma 2.2. *Given a dissipative matrix A ,*

$$\text{Ker}(A) = \text{Ker}(A^T) = \text{Ker}(A^{\text{sym}}) \cap \text{Ker}(A^{\text{skew}}).$$

Proof. It is obvious that $\text{Ker}(A) \supseteq \text{Ker}(A^{\text{sym}}) \cap \text{Ker}(A^{\text{skew}})$. On the other hand, if $v \in \text{Ker}(A)$ then $Av = 0$, and hence $v^T A^{\text{sym}} v = v^T Av = 0$. Since $A^{\text{sym}} \leq 0$, it follows that $v \in \text{Ker}(A^{\text{sym}})$. Observing that $A^{\text{skew}} = A - A^{\text{sym}}$, we have $v \in \text{Ker}(A^{\text{skew}})$. Thus $v \in \text{Ker}(A^{\text{sym}}) \cap \text{Ker}(A^{\text{skew}})$. We have proved that $\text{Ker}(A) = \text{Ker}(A^{\text{sym}}) \cap \text{Ker}(A^{\text{skew}})$. \square

Define

$$E_{A,q} = \{ x \in \mathbb{R}_+^n : A(x - q) = 0 \} \tag{5}$$

to be the affine space of equilibrium points of $X_{A,q}$.

Theorem 2.3. *Given a dissipative matrix A , each leaf of \mathcal{F}_A intersects transversely $E_{A,q}$ in a single point.*

Proof. Let V be a $k \times n$ matrix whose rows form a basis of $\text{Ker}(A)^\perp$, the space generated by the rows of A . With this notion, $A(x - q) = 0$ is equivalent to $V(x - q) = 0$. Let W be the $(n - k) \times n$ matrix used in the definition of \mathcal{F}_A , whose rows form a basis of $\text{Ker}(A^T)$. With W and V we form the $n \times n$ matrix $U = \begin{bmatrix} W \\ V \end{bmatrix}$. By lemma 2.2, $\text{Ker}(A^T) = \text{Ker}(A)$, and this implies that U is nonsingular. The intersection of a leaf $g^{-1}(c)$ of \mathcal{F}_A with the equilibria set $E_{A,q}$ is described by the system

$$x \in g^{-1}(c) \cap E_{A,q} \quad \Leftrightarrow \quad \begin{cases} W \log x = c \\ V(x - q) = 0 \end{cases} .$$

Substituting $u = \log x$, this system becomes equivalent to

$$\begin{cases} Wu = c \\ V(e^u - q) = 0 \end{cases} .$$

In order to see that each leaf of \mathcal{F}_A intersects the equilibria set $E_{A,q}$ at a single point, it is enough to see that

$$\begin{cases} Wu = c \\ V(e^u - q) = 0 \end{cases} \quad \text{and} \quad \begin{cases} Wu' = c \\ V(e^{u'} - q) = 0 \end{cases}$$

imply $u = u'$. By the mean value theorem for every $i \in \{1, \dots, n\}$ there is some $\tilde{u}_i \in [u_i, u'_i]$ such that

$$e^{u_i} - e^{u'_i} = e^{\tilde{u}_i}(u_i - u'_i),$$

which in vector notation is to say that

$$e^u - e^{u'} = D_{e^{\tilde{u}}}(u - u') = e^{\tilde{u}} * (u - u').$$

Hence

$$\begin{aligned} \begin{cases} W(u - u') = 0 \\ V(e^u - e^{u'}) = 0 \end{cases} &\Leftrightarrow \begin{cases} W(u - u') = 0 \\ VD_{e^{\tilde{u}}}(u - u') = 0 \end{cases} \Leftrightarrow \\ \left[\frac{W}{VD_{e^{\tilde{u}}}} \right] (u - u') = 0 &\Leftrightarrow U \left[\begin{array}{c|c} I & 0 \\ \hline 0 & D_{e^{\tilde{u}}} \end{array} \right] (u - u') = 0 . \end{aligned}$$

Therefore, as $\left[\begin{array}{c|c} I & 0 \\ \hline 0 & D_{e^{\tilde{u}}} \end{array} \right]$ is non-singular, we must have $u = u'$. The transversality follows from the nonsingularity of $U \left[\begin{array}{c|c} I & 0 \\ \hline 0 & D_{e^{\tilde{u}}} \end{array} \right]$. \square

3. Stably Dissipative Systems

Definition 3.1. *Given a dissipative matrix A we define its graph as $G_A = (\mathcal{V}_A, \mathcal{A}_A)$, with $\mathcal{V}_A = \mathcal{V}_\bullet \cup \mathcal{V}_\circ$, $\mathcal{V}_\bullet = \{1 \leq i \leq n : a_{ii} < 0\}$ and $\mathcal{V}_\circ = \{1 \leq i \leq n : a_{ii} = 0\}$. A pair (i, j) , with $i \neq j$, is an edge in \mathcal{A}_A iff $a_{ij} \neq 0$ or $a_{ji} \neq 0$.*

Consider a *simple* graph $G = (\mathcal{V}, \mathcal{A})$ whose vertices are colored in black and white, meaning there is a decomposition $\mathcal{V} = \mathcal{V}_\bullet \cup \mathcal{V}_\circ$ of the vertex set. We shall say that a vertex in \mathcal{V}_\circ is a \circ -vertex, while a vertex in \mathcal{V}_\bullet is a \bullet -vertex. Such graphs will be referred as *black and white graphs*.

In [11] Redheffer and Walter gave the following important property of stably dissipative matrices in terms of their associated graph.

Lemma 3.2. *If A is a stably dissipative matrix then every cycle of G_A has at least one strong link ($\bullet \rightarrow \bullet$).*

Proof. The proof is by contradiction, for otherwise we could perturb A into a non dissipative matrix. \square

Definition 3.3. *A black and white graph G is called stably dissipative iff every cycle of G contains at least a strong link, i.e., an edge between \bullet -vertices ($\bullet \rightarrow \bullet$).*

The name ‘stably dissipative’ stems from the use we shall make of this class of graphs to characterize stably dissipative matrices. See Proposition 3.5 below.

Let us say that a dissipative matrix $A \in \text{Mat}_{n \times n}(\mathbb{R})$ is *almost skew-symmetric* iff $a_{ij} = -a_{ji}$ whenever $a_{ii} = 0$ or $a_{jj} = 0$, and the quadratic form $Q(x_k)_{k \in \mathcal{V}_\bullet} = \sum_{i,j \in \mathcal{V}_\bullet} a_{ij} x_i x_j$ is negative definite.

Proposition 3.4. *Given a dissipative matrix $A \in \text{Mat}_{n \times n}(\mathbb{R})$, there is a positive diagonal matrix D such that $a_{ij} d_j = -a_{ji} d_i$ whenever $a_{ii} = 0$ or $a_{jj} = 0$, and for every $x_k \in \mathbb{R}$ with $k \in \mathcal{V}_\bullet$, $\sum_{i,j \in \mathcal{V}_\bullet} a_{ij} d_i x_i x_j \leq 0$.*

Proof. Let D be a positive diagonal matrix such that for all $x \in \mathbb{R}^n$, $Q(x) = \sum_{i,j} a_{ij} d_i x_i x_j \leq 0$. Assuming $a_{ii} = 0$, choose a vector $x \in \mathbb{R}^n$ with $x_i = 0$ and $x_k = 0$ for every $k \neq i, j$. Then for every $x_j \in \mathbb{R}$,

$$(a_{ij} d_j + a_{ji} d_i) x_j + a_{jj} d_j x_j^2 = Q(x) \leq 0 ,$$

which implies that $a_{ij} d_j + a_{ji} d_i = 0$, and everything else follows. \square

Recently, Zhao and Luo [21] gave a complete characterization of stably dissipative matrices.

Proposition 3.5. *Given $A \in \text{Mat}_{n \times n}(\mathbb{R})$, A is stably dissipative iff G_A is a stably dissipative graph and there is a positive diagonal matrix D such that AD is almost skew-symmetric.*

Proof. We outline the proof. Assuming A is stably dissipative, by lemma 3.2, G_A is stably dissipative. Take a diagonal matrix $D > 0$ according to lemma 1.1, which implies that $Q(x_k)_{k \in \mathcal{V}_\bullet} = \sum_{i,j \in \mathcal{V}_\bullet} a_{ij} d_i x_i x_j$ is negative definite. By proposition 3.4, AD is almost skew-symmetric.

Conversely, assume G_A is stably dissipative, assume AD is almost skew-symmetric, and take $\tilde{A} = (\tilde{a}_{ij})$ some close enough perturbation of A . Let \tilde{G}_A be the partial graph of G_A obtained by removing every strong link ($\bullet \dashrightarrow \bullet$). Because G_A is stably dissipative, the graph \tilde{G}_A has no cycles. We partition the vertex set $\{1, \dots, n\}$ as follows: Let V_0 be a set with an endpoint in each connected component of \tilde{G}_A . Recursively, define V_k to be the set of all vertices such that there is an edge of \tilde{G}_A connecting it to a vertex in V_{k-1} . By construction, we have a map $i \mapsto i'$, associated with this partition, such that $i' \in V_{k-1}$ for every $i \in V_k$ with $k \geq 1$, and \tilde{G}_A has an edge connecting i with i' . Then we consider the diagonal matrix $\tilde{D} = \text{diag}(\tilde{d}_j)$ whose coefficients are recursively defined by $\tilde{d}_i = d_i$ if $i \in V_0$, and

$$\tilde{d}_i = -\tilde{d}_{i'} \frac{\tilde{a}_{ii'}}{\tilde{a}_{i'i}} \quad \text{for } i \in V_k \text{ with } k \geq 1.$$

It follows by induction in k that $\tilde{d}_i > 0$ for every $i \in V_k$. For $k = 0$ this is automatic. Assuming this holds in V_{k-1} , for any $i \in V_k$ we have $\tilde{d}_{i'} > 0$, which implies that $\tilde{d}_i > 0$ because $\tilde{a}_{ii'}$ and $\tilde{a}_{i'i}$ have opposite signs. The diagonal matrix \tilde{D} is close to D because \tilde{A} is near A . Therefore, by continuity, the quadratic form $\tilde{Q}(x_k)_{k \in \mathcal{V}_\bullet} = \sum_{i,j \in \mathcal{V}_\bullet} \tilde{a}_{ij} \tilde{d}_i x_i x_j$ is negative definite. On the other hand, by definition of \tilde{d}_i , $\tilde{d}_i \tilde{a}_{ii'} + \tilde{d}_{i'} \tilde{a}_{i'i} = 0$. Since every $\circ \dashrightarrow \circ$ and $\circ \dashrightarrow \bullet$ connection links i with i' for some $i \notin V_0$, this implies that for every $(x_i) \in \mathbb{R}^n$, $\sum_{i,j=1}^n \tilde{a}_{ij} \tilde{d}_i x_i x_j \leq 0$. Hence \tilde{A} is dissipative, which proves that A is stably dissipative. \square

4. Main Results

Definition 4.1. *Given a stably dissipative graph G , we denote by $\text{SD}(G)$ the set of all dissipative matrices A with $G_A = G$.*

Our main theorem is

Theorem 4.2. *Given a stably dissipative graph G , every matrix $A \in \text{SD}(G)$ has the same rank.*

By this theorem we can define the *rank* of a stably dissipative graph G , denoted hereafter by $\text{rank}(G)$, as the rank of any matrix in $\text{SD}(G)$. Together with proposition 2.1, this implies that

Corollary 4.3. *Given a stably dissipative graph G , for every matrix $A \in \text{SD}(G)$, any stably dissipative Lotka-Volterra system with matrix A has an invariant foliation of dimension = $\text{rank}(G)$.*

Definition 4.4. *We shall say that a graph G has constant rank iff every matrix $A \in \text{SD}(G)$ has the same rank.*

With this terminology, theorem 4.2 just states that every stably dissipative graph has constant rank.

5. Simplified Reduction Algorithm

As before, let $\Gamma_{A,q}$ denote the forward limit set of (2), i.e., the set of all accumulation points of $\phi_{A,q}^t(x)$ as $t \rightarrow +\infty$. We say that a species $i \in \{1, \dots, n\}$ is *strongly dissipative* iff $\Gamma_{A,q} \subset \{x \in \mathbb{R}_+^n : x_i = q_i\}$, or equivalently $\lim_{t \rightarrow +\infty} \phi_{A,q,i}^t(x) = q_i$, for all $x \in \mathbb{R}_+^n$. Similarly, we say that a species $i \in \{1, \dots, n\}$ is *weakly dissipative* iff $\lim_{t \rightarrow +\infty} \phi_{A,q,i}^t(x)$ exists, for all $x \in \mathbb{R}_+^n$. With this terminology, the algorithm of Redheffer *et al.*, described in the introduction, is about the determination of all ‘strongly’ and ‘weakly dissipative’ species of the stably dissipative system (2). Since the algorithm runs on the graph G_A , the conclusions drawn from the reduction procedure hold for all stably dissipative systems that share the same graph G_A .

The following proposition is a slight improvement on item (b) of theorem 1.2.

Proposition 5.1. *If $\mathcal{R}(A)$ has only \bullet and \oplus -vertices then the system has an invariant foliation with a single globally attractive stationary point in each leaf.*

Proof. Combine theorem 1.2(b) with proposition 2.3. □

In [12] Redheffer and Zhiming make the following remark:

Remark 5.2. *Let A be dissipative and let every vertex \circ in G_A be replaced arbitrarily by \oplus . Then A is nonsingular iff, by algebraic manipulations, every vertex can then be replaced by \bullet .*

We shall explain this remark in terms of a simpler reduction algorithm. Denote by $E_{A,q}$ the set of all equilibria of (2), $E_{A,q} = \{x \in \mathbb{R}_+^n : A(x - q) = 0\}$. Let us say that a species $i \in \{1, \dots, n\}$ is a *restriction to the equilibria* of $X_{A,q}$ whenever $E_{A,q} \subset \{x \in \mathbb{R}_+^n : x_i = q_i\}$. Notice that every strongly dissipative species is also a restriction to the equilibria of $X_{A,q}$. Think of colouring i as black as the statement that i is a restriction to the equilibria of $X_{A,q}$. Notice that at the beginning of the reduction algorithm, described in the introduction, the weaker interpretation that all black vertices correspond to restrictions to the equilibria is also valid. If we simply do not write \oplus -vertices, but consider every \circ -vertex as a \oplus -vertex, then the reduction rules (b) and (c) can be discarded, while the first rule, (a), becomes

- (R) If all neighbours of a vertex j are \bullet -vertices, except for one vertex k , then we can color k as a \bullet -vertex.

The idea implicit in the remark above is that (R) is a valid inference rule for the weaker interpretation of the colouring statements above. Assuming that every \circ -vertex is a \oplus -vertex amounts to looking for restrictions on the equilibria set $E_{A,q}$ instead of the attractor $\Gamma_{A,q}$. Let us still call *reduced graph* to the graph, denoted by $\mathcal{R}_*(G)$, obtained from G by successively applying rule (R) alone until it can no longer be applied. The previous considerations show that

Proposition 5.3. *Given a stably dissipative matrix A , every \bullet -vertex of $\mathcal{R}_*(G_A)$ is a restriction to the equilibria of $X_{A,q}$.*

We shall write $\mathcal{R}_*(G) = \{\bullet\}$ to express that all vertices of $\mathcal{R}_*(G)$ are \bullet -vertices.

Corollary 5.4. *If G is a stably dissipative graph such that $\mathcal{R}_*(G) = \{\bullet\}$ then every matrix $A \in \text{SD}(G)$ is nonsingular. In particular G has constant rank.*

Proof. Given $A \in \text{SD}(G)$, by Proposition 5.3 we have $E_{A,q} = \{q\}$, which automatically implies that A is nonsingular. \square

In fact, the converse statement of this corollary holds by remark 5.2.

Proposition 5.5. *Let A be stably dissipative matrix. If A is nonsingular then $\mathcal{R}_*(G_A) = \{\bullet\}$.*

6. Proofs

We call any extreme \circ -vertex of G a \circ -*endpoint* of G .

Lemma 6.1. *If a stably dissipative graph G has no \circ -endpoints then $\mathcal{R}_*(G) = \{\bullet\}$.*

Proof. Let G be a stably dissipative graph with no \circ -endpoints. Assume, by contradiction, that $\mathcal{R}_*(G) \neq \{\bullet\}$. We shall construct a cycle in $\mathcal{R}_*(G)$ with no $\bullet\text{--}\bullet$ edges. Since every \circ -vertex of $\mathcal{R}_*(G)$ is also a \circ -vertex of G , this will contradict the assumption that G is stably dissipative. In the following construction we always refer to the vertex coloring of $\mathcal{R}_*(G)$. Take j_0 to be any \circ -vertex. Then, given j_k take a neighbouring vertex j_{k+1} to be another \circ -vertex, if possible, or a \bullet -vertex otherwise. While the path is simple (no vertex repetitions) it can not end at some \circ -endpoint, and it can not contain any $\bullet\text{--}\bullet$ edge because whenever we arrive to a \bullet -vertex from a \circ -one we can always escape to another \circ -vertex. In fact, no \bullet -vertex can be linked to a single \circ -vertex since otherwise we could reduce it to a \bullet -vertex by applying rule (R). By finiteness this recursively defined path must eventually close, hence producing a cycle with no $\bullet\text{--}\bullet$ edges. \square

Given a stably dissipative graph G and some \circ -endpoint $i \in \mathcal{V}_\circ$, we define the *trimmed* graph $T_i(G)$ as follows: Let $i' \in \mathcal{V}$ be the unique vertex connected to i by some edge of G . Then $T_i(G)$ is the partial graph obtained from G by removing every edge incident with i' except with i . The trimming operation preserves the stable dissipativeness of graph, i.e., $T_i(G)$ is stably dissipative whenever G is. This follows by definition 3.3 because $T_i(G)$ is obtained by removing some edges from G .

Similarly we define the *trimmed matrix* $T_i(A)$ as follows: Annihilate every entry of row i' , except for $a_{i'i}$ and $a_{i'i'}$, and annihilate every entry of column i' , except for $a_{ii'}$



Figure 1: A graph G and its trimmed graph $T_i(G)$.

and $a_{i'i'}$.

$$A = \begin{bmatrix} \cdot & 0 & \cdot & * & \cdot \\ 0 & 0 & 0 & a_{ii'} & \cdot \\ \cdot & 0 & \cdot & * & \cdot \\ * & a_{i'i} & * & a_{i'i'} & * \\ \cdot & 0 & \cdot & * & \cdot \end{bmatrix} \quad T_i(A) = \begin{bmatrix} \cdot & 0 & \cdot & 0 & \cdot \\ 0 & 0 & 0 & a_{ii'} & \cdot \\ \cdot & 0 & \cdot & 0 & \cdot \\ 0 & a_{i'i} & 0 & a_{i'i'} & 0 \\ \cdot & 0 & \cdot & 0 & \cdot \end{bmatrix}$$

The ‘*’ above represent entries of A that are annihilated in $T_i(A)$.

Lemma 6.2. *Let $i \in \mathcal{V}_\circ$ be some \circ -endpoint of a stably dissipative graph G . If $A \in \text{SD}(G)$ then $T_i(A) \in \text{SD}(T_i(G))$ and $\text{rank}(T_i(A)) = \text{rank}(A)$.*

Proof. Take $A \in \text{SD}(G)$ and let $A' = T_i(A)$, where i is some \circ -endpoint. Denote, respectively, by col_j and row_j the j^{th} column and the j^{th} row of A , and denote by col'_j and row'_j the j^{th} column and the j^{th} row of the trimmed matrix. Since i is a \circ -endpoint, $a_{ii'}$ is the only nonzero entry in row_i , and $a_{i'i}$ is the only nonzero entry in col_i . Then the trimmed matrix A' is obtained from A by applying the following Gauss elimination rules, either simultaneously or in some arbitrary order

$$\begin{aligned} \text{row}'_j &:= \text{row}_j - \frac{a_{ji'}}{a_{ii'}} \text{row}_i & j \neq i' , \\ \text{col}'_j &:= \text{col}_j - \frac{a_{i'j}}{a_{i'i}} \text{col}_i & j \neq i' . \end{aligned}$$

Because Gauss elimination preserves the matrix rank we have $\text{rank}(A') = \text{rank}(A)$. To finish the proof, it is enough to see now that A' is stably dissipative. We use proposition 3.5 for this purpose. First, $G_{A'} = T_i(G)$ is stably dissipative as observed above. Let D be a positive diagonal matrix such that AD is almost skew-symmetric. In view of proposition 3.5, we only need to prove that $A'D$ is also almost skew-symmetric. Notice that G and $T_i(G)$ share the same black and white vertices. If $a'_{kk} = 0$ or $a'_{jj} = 0$ then also $a_{kk} = 0$ or $a_{jj} = 0$. Hence, because AD is almost skew-symmetric, $a_{kj} d_j = -a_{jk} d_k$. Looking at the Gauss elimination rules above, we have $a'_{kj} = a_{kj}$ and

$a'_{jk} = a_{jk}$, or else $a'_{kj} = a'_{jk} = 0$. In either case we have $a'_{kj} d_j = -a'_{jk} d_k$. Finally, we need to see that $Q'(x_\ell)_{\ell \in \mathcal{V}_\bullet} = \sum_{k,j \in \mathcal{V}_\bullet} a'_{kj} d_j x_k x_j$ is a negative definite quadratic form. If i' is a \circ -vertex then $Q'(x_\ell)_{\ell \in \mathcal{V}_\bullet} = \sum_{k,j \in \mathcal{V}_\bullet} a_{kj} d_j x_k x_j$ is negative definite because AD is almost skew-symmetric. Otherwise, if i' is a \bullet -vertex, given a nonzero vector $(x_\ell)_{\ell \in \mathcal{V}_\bullet}$ we define $(x'_\ell)_{\ell \in \mathcal{V}_\bullet}$ letting $x'_\ell = x_\ell$ for $\ell \neq i'$, while $x'_{i'} = 0$. Then

$$Q'(x_\ell)_{\ell \in \mathcal{V}_\bullet} = \underbrace{a_{i'i'}}_{<0} d_{i'} x_{i'}^2 + \underbrace{\sum_{k,j \in \mathcal{V}_\bullet} a_{kj} d_j x'_k x'_j}_{=Q(x'_\ell)_{\ell \in \mathcal{V}_\bullet} \leq 0} < 0,$$

since $(x_\ell)_{\ell \in \mathcal{V}_\bullet} \neq 0$ implies that either $x_{i'} \neq 0$ or else $(x'_\ell)_{\ell \in \mathcal{V}_\bullet} \neq 0$. This proves that Q' is negative definite. \square

As a simple corollary of the previous lemma we obtain

Lemma 6.3 (Trimming lemma). *Let $i \in \mathcal{V}_\circ$ be some \circ -endpoint of a stably dissipative graph G . If $T_i(G)$ has constant rank then so has G , and $\text{rank}(G) = \text{rank}(T_i(G))$.*

We can now prove theorem 4.2.

Proof. Define recursively a sequence of graphs G_0, G_1, \dots, G_m , with $G_0 = G$, and where $G_{i+1} = T_{j_i}(G_i)$ for some \circ -endpoint j_i of G_i . This sequence will end at some graph G_m with no \circ -endpoint. By Lemma 6.1 we have $\mathcal{R}_*(G_m) = \{\bullet\}$. The connected components of G_m are either reducible to \bullet -vertices by iteration of rule (R), or else composed by \circ -vertices alone. Since the \circ -components can not be trimmed anymore, they must be either formed of a single \circ -vertex, or else a single \circ - \circ edge. By corollary 5.4, G_m has constant rank. Finally, applying inductively Lemma 6.3 we see that all graphs G_i have constant rank. Hence G , in particular, has constant rank. \square

Remark 6.4. *The previous proof gives a simple recipe to compute the rank of a graph. Trim G while possible. In the end, discard the single \circ -vertex components and count the remaining vertices.*

Table 1: Some graph trimming examples.

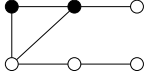
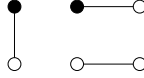
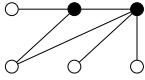
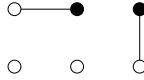
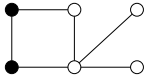
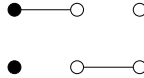
Original graph	Trimmed graph	Graph rank
		6
		4
		5

7. Trimming Effect on Dynamics

In this last section we use an example to describe the effect of trimming a stably dissipative matrix on the underlying dynamics.

Consider the system

$$E = \begin{cases} \dot{x}_1 = x_1((x_2 - 1) + (x_7 - 1)) \\ \dot{x}_2 = x_2(-2(x_1 - 1) + (x_3 - 1)) \\ \dot{x}_3 = -x_3(x_2 - 1) \\ \dot{x}_4 = x_4((x_5 - 1) - (x_7 - 1)) \\ \dot{x}_5 = x_5(-2(x_4 - 1) + (x_6 - 1)) \\ \dot{x}_6 = -x_6(x_5 - 1) \\ \dot{x}_7 = x_7(-(x_1 - 1) + (x_4 - 1) - (x_7 - 1)), \end{cases}$$

with interaction matrix

$$A = \left[\begin{array}{ccc|ccc|c} 0 & 1 & 0 & 0 & 0 & 0 & 1 \\ -2 & 0 & 1 & 0 & 0 & 0 & 0 \\ 0 & -1 & 0 & 0 & 0 & 0 & 0 \\ \hline 0 & 0 & 0 & 0 & 1 & 0 & -1 \\ 0 & 0 & 0 & -2 & 0 & 1 & 0 \\ 0 & 0 & 0 & 0 & -1 & 0 & 0 \\ \hline -1 & 0 & 0 & 1 & 0 & 0 & -1 \end{array} \right]$$

and fixed point $q = (1, 1, 1, 1, 1, 1, 1)$. E has associated graph G_A represented in figure 2.

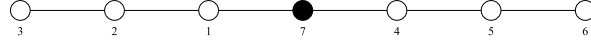

Figure 2: Associated graph of matrix A , $G(A)$.

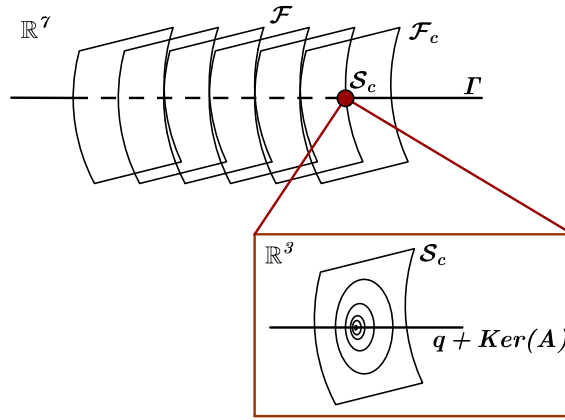

Figure 3: Phase portrait of a system E .

The null space, $\text{Ker}(A)$, is generated by the vector $(1, 0, 2, 1, 0, 2, 0)$. Hence the foliation \mathcal{F} , with leaves \mathcal{F}_c given by

$$\mathcal{F}_c = \{x \in \mathbb{R}^7 : \log x_1 + 2 \log x_3 + \log x_4 + 2 \log x_6 = c\},$$

is an invariant foliation with dimension 6 in \mathbb{R}^7 . The system's phase portrait is represented in figure 3, being the attractor a 3-plan transversal to \mathcal{F} given by

$$\Gamma = \{x \in \mathbb{R}^7 : x_1 = x_4, x_2 = x_5, x_3 = x_6, x_7 = 1\}.$$

The intersection of each leaf \mathcal{F}_c with Γ is a surface \mathcal{S}_c given by

$$\mathcal{S}_c = \mathcal{F}_c \cap \Gamma = \{(x_1, x_2, x_3, x_1, x_2, x_3, 1) : \log x_1 + 2 \log x_3 = \frac{c}{2}\},$$

which is foliated into invariant curves by the level sets of h , defined in (3). Note that \mathcal{S}_c corresponds to an invariant leaf of the conservative system with graph $\circ - \circ - \circ$.

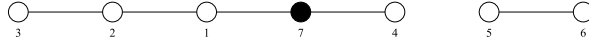

Figure 4: The trimmed graph of G , $T_6(G)$.

With the first trim on G we get the graph $T_6(G)$ represented in figure 4.

This corresponds to annihilate the entries $(4, 5)$ and $(5, 4)$ of the original matrix A . Notice that the components x_5 and x_6 of the system are independent of the rest. Hence the dynamics of this new system is the product of two independent LV systems represented in figure 5.

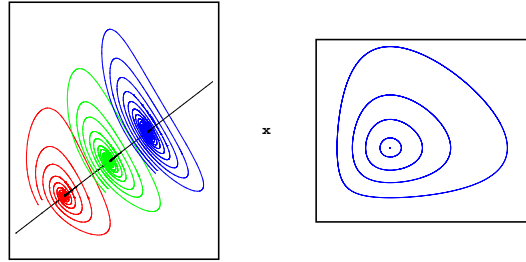

Figure 5: Representation of the dynamic of the system E_1 .

The five dimensional system on the left of figure 5 has a straight line of equilibria. Moreover it leaves invariant a foliation of dimension four with a single globally attractive fixed point on each leaf. The right-hand side system is a typical conservative predator-prey.

Now we have two different possibilities of trimming the graph $T_6(G)$: we can either choose the \circ -endpoint 3 or else 4. In the first case we get the graph $T_3(T_6(G))$ represented in figure 6, whose dynamics is illustrated in figure 7.

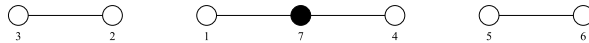

Figure 6: The trimmed graph $T_3(T_6(G))$ of $T_6(G)$.

The three dimensional system in the middle of figure 7 has a straight line of equilibria. Moreover it leaves invariant a foliation of dimension two with a single globally attractive fixed point on each leaf. The left and right-hand side systems are typical conservative predator-preys.

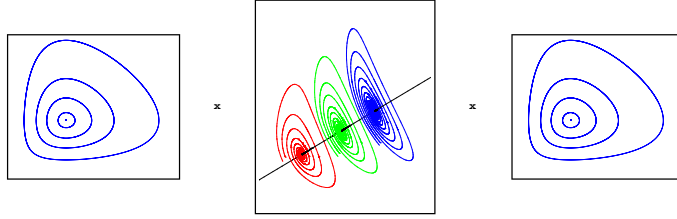

Figure 7: Representation of the system's dynamics associated to the graph $T_3(T_6(G))$.

In the second case we get the graph $T_4(T_6(G))$ represented in figure 8, whose dynamics is depicted in figure 9.



Figure 8: The trimmed graph $T_4(T_6(G))$ of $T_6(G)$.

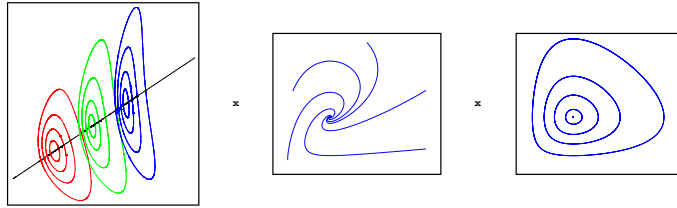

Figure 9: Representation of the system's dynamics associated to the graph $T_4(T_6(G))$.

Here, the left-hand side three dimensional system is conservative, leaving invariant a foliation of dimension two transversal to a straight line of equilibria. The middle and right-hand side systems are typical predator-prey, respectively, dissipative and conservative.

Trimming $T_4(T_6(G))$ choosing the \circ -endpoint 1 we get the graph $T_1(T_4(T_6(G)))$ represented in figure 10, whose dynamics is a product of three predator-prey systems, illustrated in figure 11, with a one dimensional system consisting of equilibria.

Notice that by trimming $T_3(T_6(G))$ we obtain an isomorphic graph to the one in figure 10.

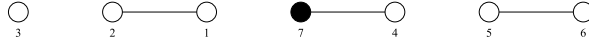

Figure 10: The trimmed graph $T_1(T_4(T_6(G)))$ of $T_4(T_6(G))$.

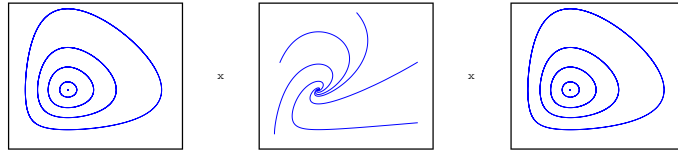

Figure 11: Representation of the system's dynamics associated to the graph $T_1(T_4(T_6(G)))$.

Acknowledgments

The first author was partially supported by Fundação para a Ciência e Tecnologia through the project "Randomness in Deterministic Dynamical Systems and Applications" (PTDC/MAT/105448/2008).

References

- [1] van den Driessche, P., Zeeman, M. L., Three-dimensional competitive Lotka-Volterra systems with no periodic orbits, *SIAM J. Appl. Math.*, **58**, (1998), 227-234.
- [2] Duarte, P., Fernandes, R. L., Oliva, W. M., Dynamics of the attractor in the Lotka-Volterra, *J. Diff. Eqs.*, **149**, (1998), 143-189.
- [3] Hirsch, M. W., Systems of differential equations which are competitive or cooperative I: limit sets, *SIAM J. Math. Anal.*, **13**, (1982), 167-179.
- [4] Hirsch, M. W., Systems of differential equations which are competitive or cooperative III: competing species, *Nonlinearity*, **1**, (1988), 51-71.
- [5] Hofbauer, J., Sigmund, K., Evolutionary Games and Population Dynamics, *Cambridge University Press*, Cambridge, 1998.
- [6] Hofbauer, J., So, J. W. H., Multiple limit cycles for three dimensional competitive Lotka-Volterra systems, *Appl. Math. Lett.*, **7**, (1994), 65-70.

- [7] Karakostas, G., Gyori, I., Global stability in job systems, *J. Math. Anal. Appl.*, **131**, (1988), 85-96.
- [8] LaSalle, J., Stably theory for ordinary differential equations, *J. Diff. Eqs.*, **4**, (1968), 57-65.
- [9] Redheffer, R., Volterra multipliers I, *SIAM J. Alg. Disc. Math.*, **6**, (1985), 592-611.
- [10] Redheffer, R., A new class of Volterra differential equations for wich the solution are globally asymptotically stable, *J. Diff. Eqs.*, **82**, (1989), 251-268.
- [11] Redheffer, R., Walter, W., Solution of the stability problem for a class of generalized Volterra prey-predator systems, *J. Diff. Eqs.*, **52**, (1984), 245-263.
- [12] Redheffer, R., Zhou, Z., Global asymptotic stability for a class of many-variable Volterra prey-predator system, *Nonlinear Anal. - Theory Methods Appl.*, **5**, (1981), 1309-1329.
- [13] Redheffer, R., Zhou, Z., A class of matrix connected with Volterra prey-predator equation, *SIAM J. Alg. Disc. Math.*, **3**, (1982), 122-134.
- [14] Smale, S., On the differential equations of species in competition, , *J. Math. Biol.*, **3**, (1976), 5-7.
- [15] Smith, H. L., On the asymptotic behavior of a class of deterministic models of cooperating species, , *SIAM J. Appl. Math.*, **46**, (1986), 368-375.
- [16] Takeuchi, Y., Global Dynamical Properties of Lotka-Volterra Systems, *World Scientific*, Singapore, 1996.
- [17] Volterra, V., Leçons sur la Théorie Mathématique de la Lutte pour la Vie, *Gauthier-Villars et C^{ie}*, Paris, 1931.
- [18] Zeeman, M. L., Hopf bifurcations in competitive three dimensional Lotka-Volterra systems, *Dynam. Stab. Syst.*, **8**, (1993), 189-216.
- [19] Zeeman, M. L., Extinction in competitive Lotka-Volterra systems, *Proc. Amer. Math. Soc.*, **123**, (1995), 87-96.

- [20] Zeeman, M. L., On diverted periodic orbits in three-dimensional competitive Lotka-Volterra systems, in Martelli, M., Cooke, K., Cumberbatch, E., Tang, B., Thieme, H. (Eds.), *Differential Equations and Applications to Biology and to Industry* *World Scientific*, Singapore, 1995.
- [21] Zhao, X., Luo, J., Classification and dynamics of stably dissipative Lotka-Volterra systems, *Int. J. Non-linear Mech.*, **45**, (2010), 603-607.